



Applied Energy Technologies

# Rayport™

## *AET-430 Installation Guide*

### Contents

1. Installer Notes .....	P2
2. Loading Calculations .....	P3
3. Installation .....	P4-10
a. Parts List .....	P4
b. Tool List .....	P5
c. Assembly .....	P6-11

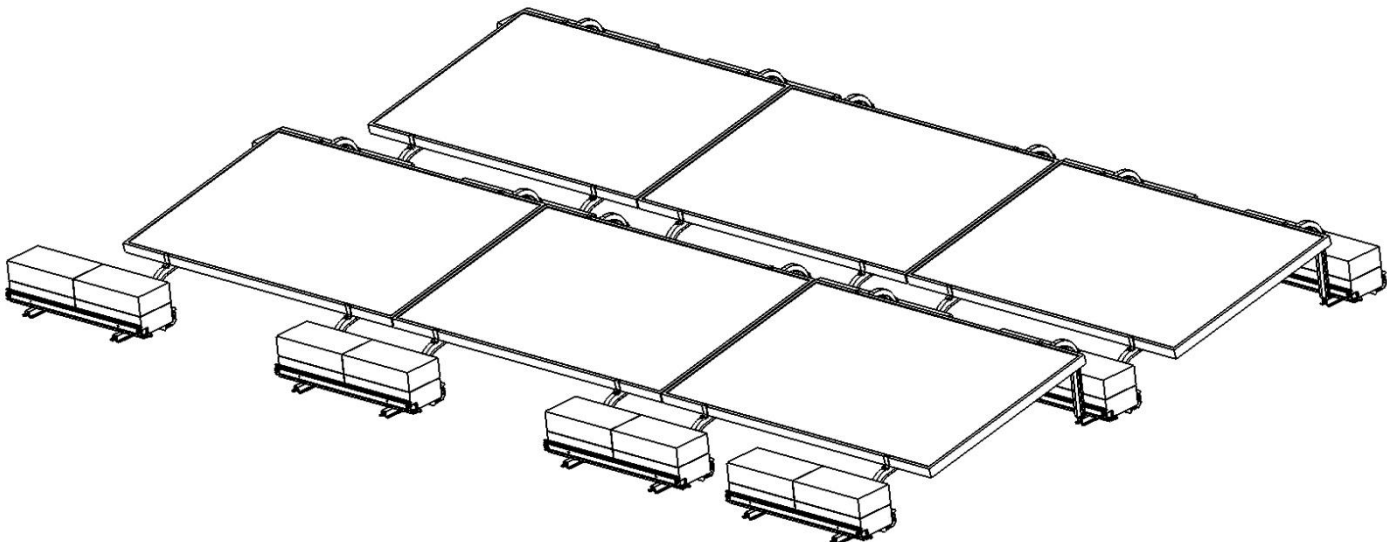

## 1. Installer Notes

Thank you for purchasing AET's Rayport™ flat roof top ballasted racking system manufactured in Maumee, Ohio and Toronto, Canada. The system has been configured to accommodate both framed (30-51mm thick) or unframed modules with either one or two modules per support rail. Designed with the installer in mind, the Rayport™ system allows for a top down installation, common fasteners, and integrated grounding. The Rayport™ system has been listed per the UL1703/2703 standards to withstand a load of 30 psf and a fuse rating of 25 amps. The Rayport™ racking system has been internally tested to withstand loads as high as 50 psf. (for loads above 50 psf an optional support arm is available). The maximum module width or N-S dimension for the Rayport™ system is 1440mm (56.69").

**Warning:** Roofs that are intended to support the Rayport™ racking system should be classified with an A, B or C Fire Rating, depending on the regional location and codes.

## 2. Array Layout

$W_A$  = Array Width (east/west)  
 $W_M$  = Module Width (east/west dimension)  
 $C$  = Number of Columns  
 $G$  = Gap Between Modules (normally  $\frac{1}{4}$ " )

$$W_A = (W_M \times C) + (G \times (C - 1))$$

Assuming a 58.3" wide module for the example below:

$$W_A = (58.3 \times 7) + (0.25 \times (7 - 1))$$

$$W_A = 409.6" \text{ or } 34.1 \text{ feet}$$

$L_A$  = Array Length (north/south)  
 $D_R$  = Repeating Rack Dimension  
 $R$  = Number of Rows  
 $T$  = Tray Dimension

$$L_A = (D_R \times R) + T$$

Assuming a standard 10° rail and narrow tray for the example below:

$$L_A = (58.62 \times 4) + 10.6$$

$$L_A = 245.08" \text{ or } 20.42 \text{ feet}$$

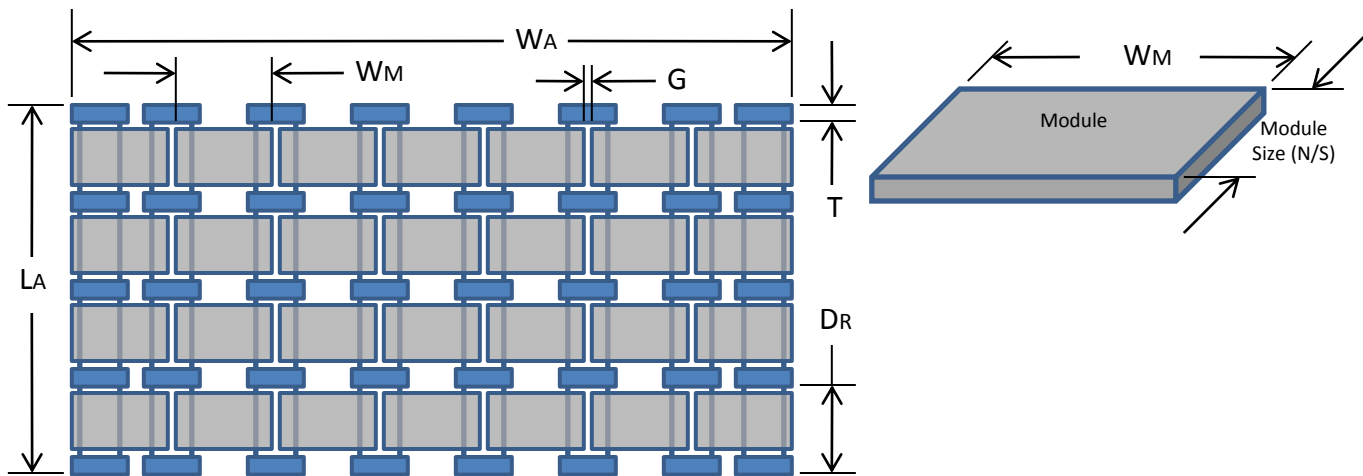

Note: Typical module orientation is landscape

***The Repeating Dimension varies depending on the Support Rail and Ballast Tray. The Repeating Dimension should be verified on the layout provided by AET.***

## 3a. Installation - Parts List

### Support Rail

*-Multiple design configurations are available based on customer design constraints.*



### Ballast Tray Assembly (Standard Narrow Tray Shown)

*-Multiple design configurations are available based on customer design constraints.*

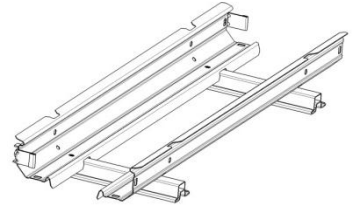

### Module Clamp

Listed per UL1703/2703

*-Clamps available for modules ranging from 30-51mm thick.*



### Bolt

1/4-20 Hex Flange HD w/ Lock Patch



## 3b. Installation - Tool List

Layout/BOM from AET

Ballast / Support Rail Spacer Bar (Available from AET)

3/8" Socket w/ Ratchet or Impact Driver

100 ft. Tape Measure

Mason String or Chalk Line

Industrial Adhesive (as needed)

Torque Wrench

## 3c. Installation – Assembly

- 1. Establish perpendicular lines for array alignment:** Using string or a chalk line, create a east/west line. Typically, this would be the front or rear of the PV array. Next, establish a north/south line perpendicular to the first line near the center of the array using a multiple of a 3-4-5 triangle. Larger triangles of 15-20-25 or 30-40-50 should be used for larger arrays.

It's important to perform the layout independent of existing building structure. Not all parapets or roof edges are square or parallel which may cause alignment issues with the PV array.

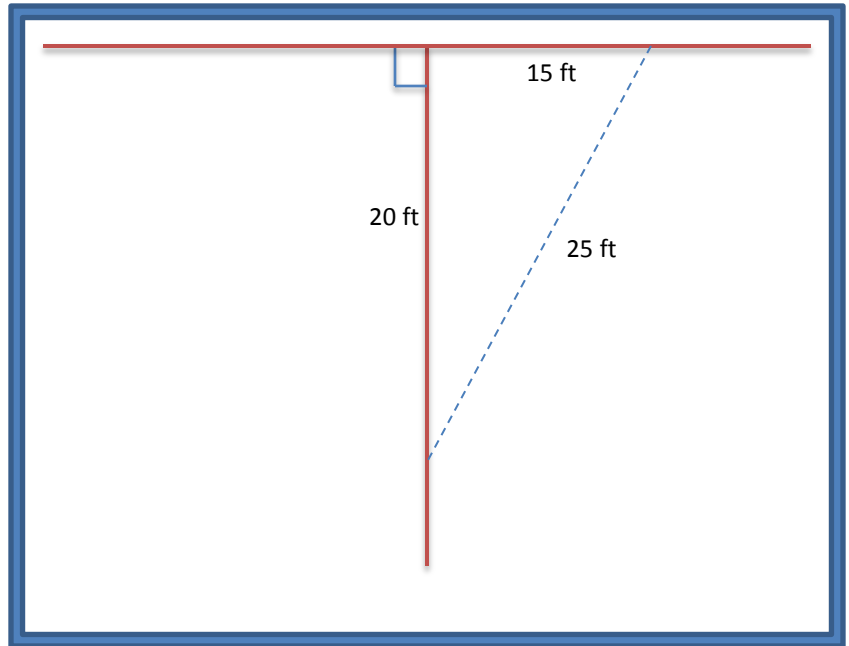

- 2. Setting the Spacer Bar:** Loosen both Lever Knobs on the Spacer Bar to allow the ends to slide freely. Place the Spacer Bar on the east/west dimension of the module. The two small tabs on the ends of the Spacer Bar should nest tightly against the module. Lock the ends of the Spacer Bar by tightening the Lever Knobs. **Note:** The Spacer Bar adds an additional  $\frac{1}{4}$ " to the overall length of each module. **This spacing is required between modules for thermal growth.**

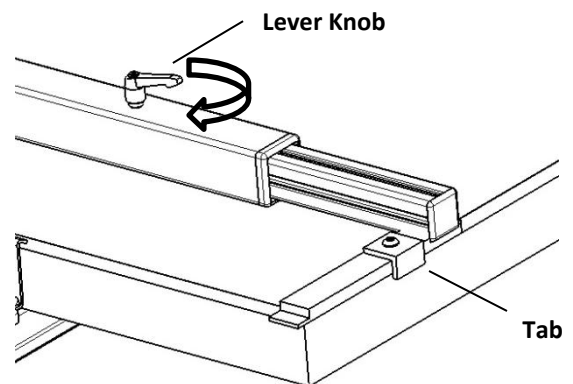
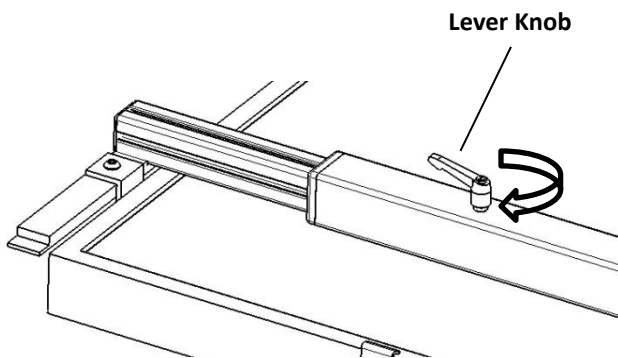
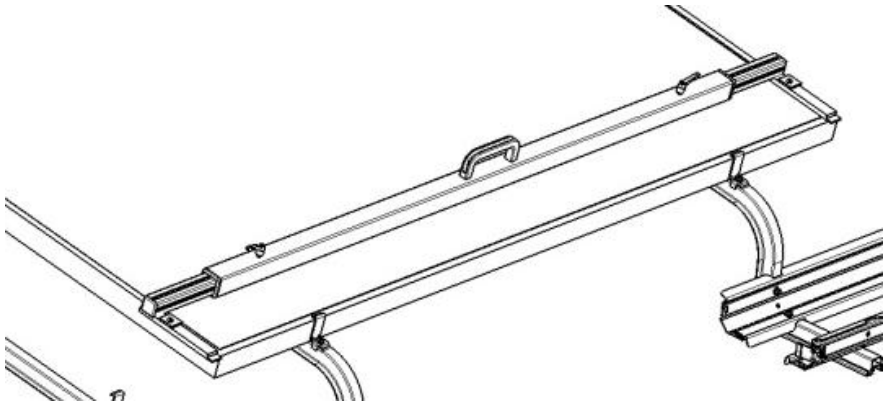

### 3c. Installation - Assembly

**3. Assemble racking units:**

Assemble (2) support rails to (2) ballast trays using ¼-20 bolts. Attach (2) additional support rails and a ballast tray as shown.

**Note:** Torque all fasteners to 60 in-lb (5 ft-lb)

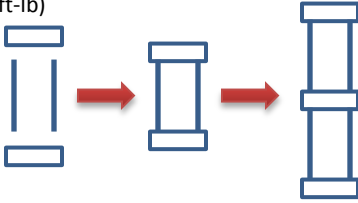

**4. Positioning the first racking units.**

Starting from the optimal North/South line location, position the first rack assembly so the ballast tray ends align to the North/South construction line and the ballast tray front align with the East/West line that were established in step 1. Once the first assembly is in position add ballast blocks to the first two trays. Using the Spacer Bar that was set to length in step 2, position the next assembly by placing the Spacer Bar into the corresponding notches in the trays, as shown.

**Note:** The spacing between assemblies will be closer together on the extreme east and west ends of the array, as shown below.

**Odd number of modules centered per row:**  
Ballast tray end alignment to North/South line.  
**Formula for North/South line from Array Center or Optimal location:**  
*(see page #3 for reference)*  
**Distance from the East/West edge of the Array to North/South Line:**  
**= (# of Modules)x(WM + 0.25") ± (½WM) ± 16"**

**Even number of modules centered per row:**  
Ballast tray end alignment to North/South line.  
**Formula for North/South line from Array Center or Optimal location:**  
*(see page #3 for reference)*  
**Distance from the East/West edge of the Array to North/South Line:**  
**= (# of Modules)x(WM + 0.25") ± 16"**

**5. Layout first two rows of racking.**

Repeat steps 3 and 4 for the number of racking units required for an entire row of modules. The number of rack assemblies required is one more than the number of modules in a row. For example, 7 modules in a row requires 8 columns of rack assemblies.

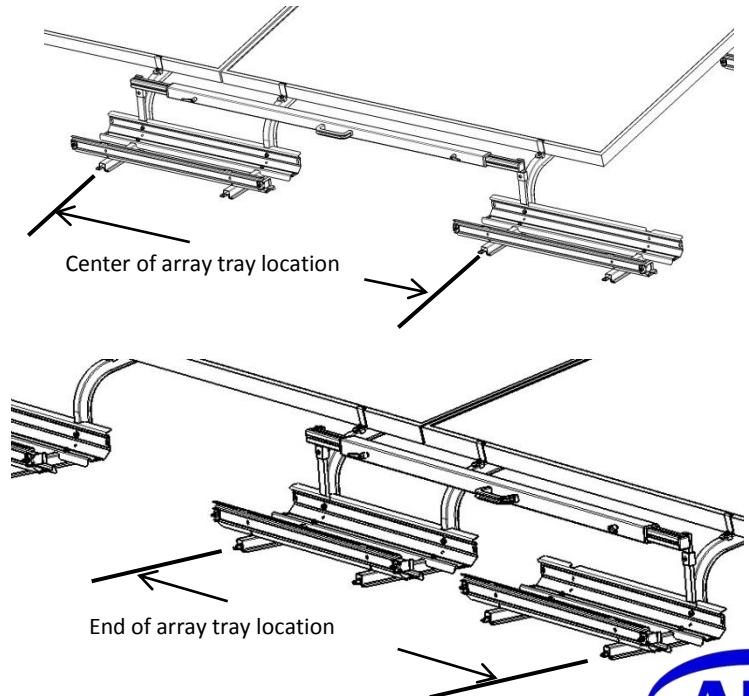

### 3c. Installation - Assembly

**6. Begin to install first row of modules.**

Load the ballast trays with the specified number of ballast bricks per AET supplied layout. Ballast should be added to the trays in front and behind the module prior to installing the module. Once the four corners around the module have been secured with ballast, the module can be installed using the provided 1/4-20 bolts and Module Clamps. Torque fasteners to 60 in-lb (5 ft-lb).

**Note:** Grounding of the module has been integrated into the module clamp and has been listed per UL1703/2703 .

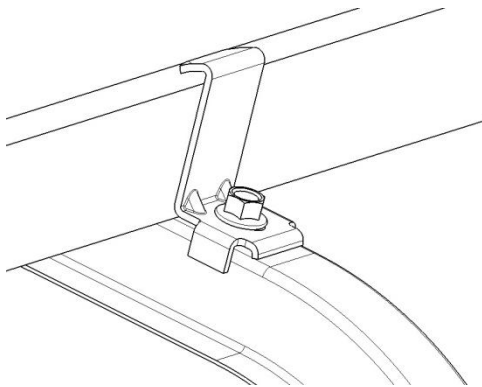
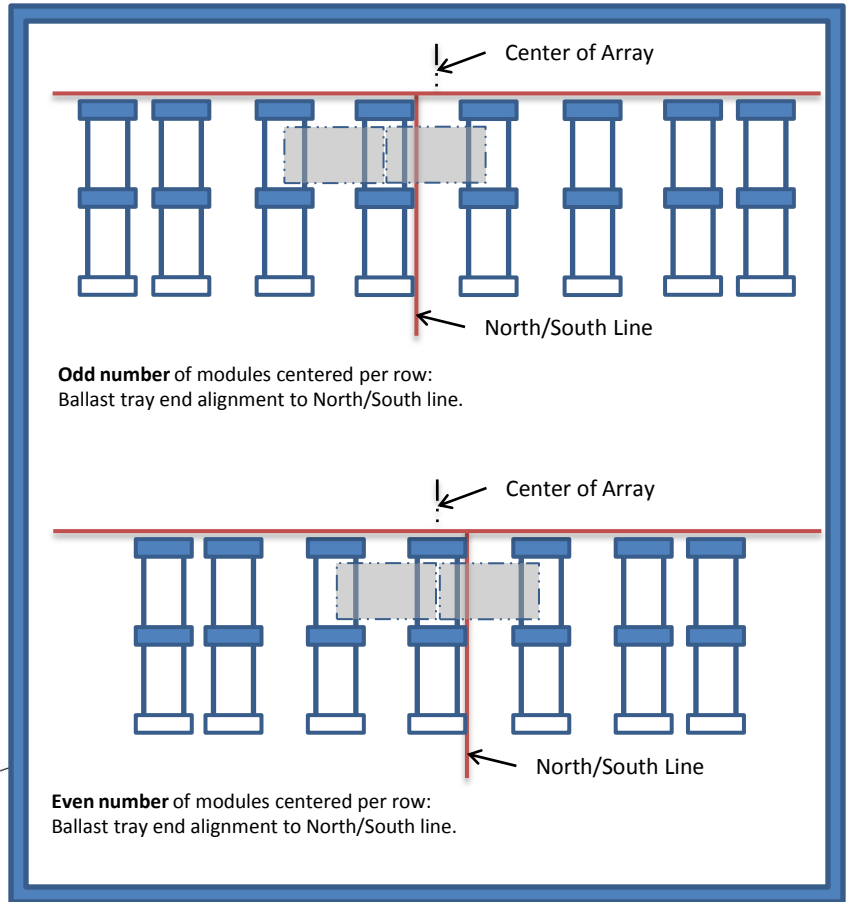

Module Clamp installed with 1/4-20 bolt.



Installed position with integrated pierce points penetrating the anodize frame coating.

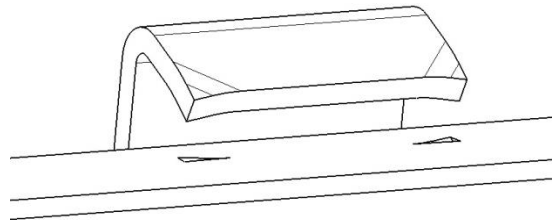

Resulting penetrating points through the anodize frame coating.

### 3c. Installation - Assembly

**7. Finish installing modules in 1st row.**

Working from the center out towards the sides, continue spacing the rack assemblies with the spacer bar and installing ballast in the trays. Follow with the installation of the modules prior to moving on to the next row. There should be approximately ¼" gap between modules.

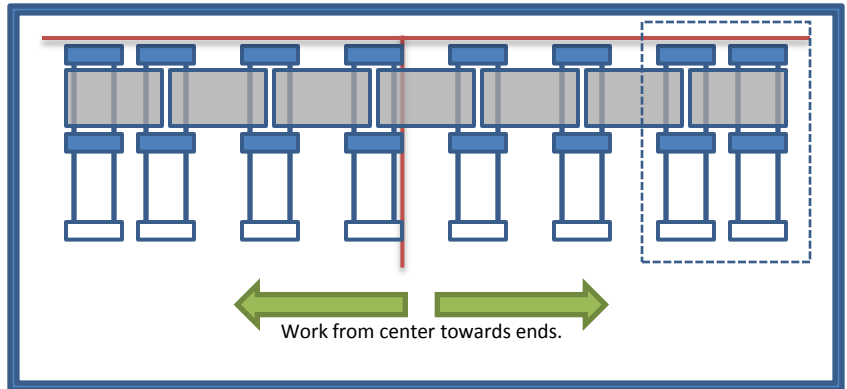

**8. End module racking location.**

The end columns located at the extreme east and west of the system array may be located entirely under the last modules (as shown below and on page #7). This will cause three support rails to be located under the end modules in each row.

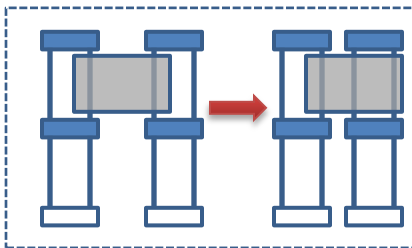

**9. Build additional rows of racking.**

Additional rows of racking can now be assembled.

Note: Connect the support rail and ballast tray assemblies prior to installing ballast bricks.

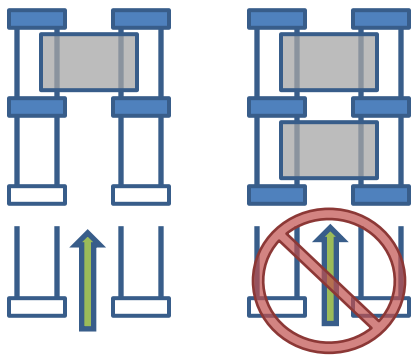

CORRECT

NOT  
CORRECT

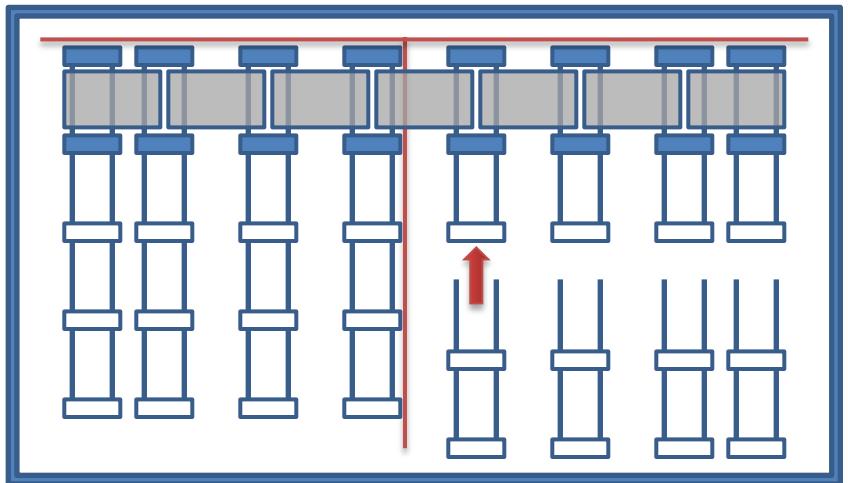

## 3c. Installation - Assembly

### 10. Install second row of modules.

Now that the third and fourth rows of racking are assembled, position and ballast each tray as described in steps 4 and 5. The second row of PV modules can now be installed starting from the center of the array.

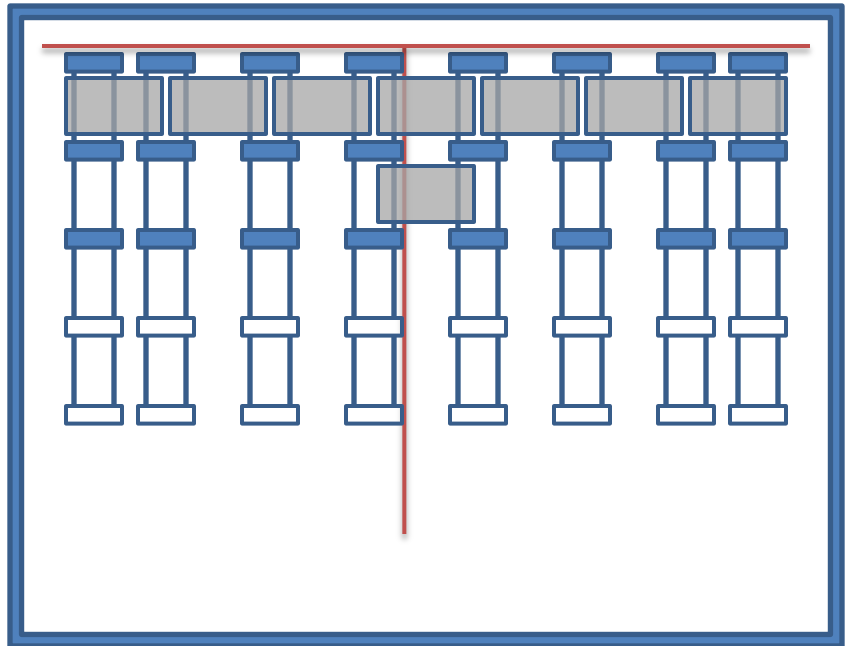

### 11. Complete the module installation.

Once the last row of modules and ballast have been installed, the modules can be wired and the rack can be grounded.

Holes for grounding lugs are provided on the back of every support rail, see figure shown below. However, due to the design of the racking, grounding wire only needs to be installed every 20 rows in the N and S direction. Only one rail per tray in the row being grounded is required to use a lug.

